

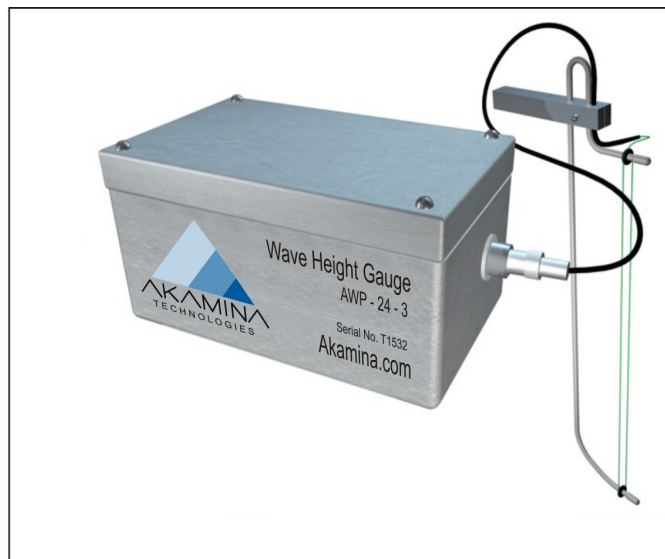

# AWP-24-3

## Wave Height Gauge User's Guide



**Issue: 1.5**  
**Status: Released**  
**18-Dec-2014**

**Prepared by**  
**Akamina Technologies Inc.**

---

**Akamina Technologies Inc.**  
**91 Norice St., Ottawa, Ontario K2G 2X9, CANADA**  
**TEL: +1 613 454-8062**  
**[www.akamina.com](http://www.akamina.com) [support@akamina.com](mailto:support@akamina.com)**

# Table of Contents

<b>1. INTRODUCTION.....</b>	<b>3</b>
1.1 WAVE HEIGHT GAUGE OVERVIEW.....	3
<b>2. AWP-24-3 MAIN COMPONENTS.....</b>	<b>4</b>
2.1 ENCLOSURE.....	4
2.2 CONNECTORS AND CABLES.....	4
2.3 AWP-24-3 ELECTRONICS.....	5
2.4 EXTERNAL CONTROL CONNECTOR.....	6
2.5 WAVE PROBE HEAD.....	6
<b>3. CONFIGURATION.....</b>	<b>8</b>
3.1 CONFIGURATION PROCEDURE.....	8
<b>4. OUTPUT RANGE ADJUSTMENT.....</b>	<b>9</b>
4.1 CALIBRATION.....	9
<b>5. MINOR ADJUSTMENTS TO SENSING WIRE TENSION.....</b>	<b>10</b>
5.1 INSTRUCTIONS.....	10
<b>6. AKAMINA PRODUCT WARRANTY.....</b>	<b>11</b>
6.1 LIMITED WARRANTY.....	11
6.2 REMEDIES .....	11

# 1. INTRODUCTION

The AWP-24-3 from Akamina Technologies is a capacitance-type precision wave height measurement gauge. For accurate measurements and continued reliable operation please read this manual carefully. We also recommend reading the application note: <http://www.akamina.com/Reports/MinNoiseData.pdf>, in order to minimize noise and increase accuracy.

The AWP-24-3 is easy to configure and is ready to use with the push of a button. There are no dials to turn or jumpers to set. The configuration does not require any extra equipment.

The AWP-24-3 is the only wave height gauge on the market that measures capacitance using digital techniques, providing high accuracy measurements of wave heights or water levels. The measured capacitance is converted to an analogue voltage that can be measured with a voltmeter or a data acquisition system depending on your specific needs. The AWP-24-3 provides an output voltage that is proportional to the level of water. A simple calibration procedure allows the highly linear relationship between the water level and the voltage to be determined. This relationship is then used to convert the measured voltage to wave heights or water levels.

## 1.1 Wave Height Gauge Overview

The Akamina wave height gauge system consists of two main components. These are:

- AWP-24-3 electronics mounted in an enclosure
- wave probe head and mounting clamp. The probe is partially submerged in water during measurements.

The AWP-24-3, the wave probe head, and a typical tripod for laboratory use are shown in Figure 1-1.

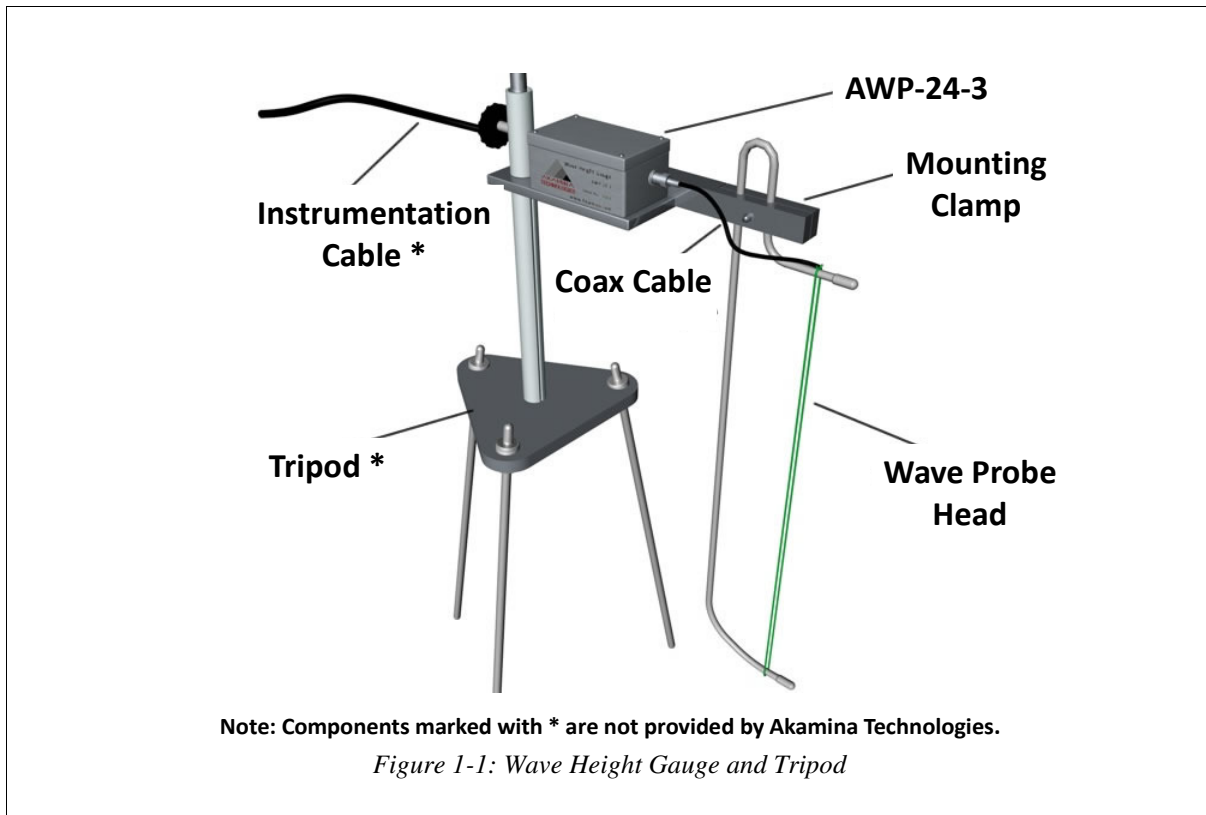

## 2. AWP-24-3 MAIN COMPONENTS

### 2.1 Enclosure

The AWP-24-3 uses a heavy-duty, rugged, watertight, diecast aluminium alloy enclosure that is suitable for indoor or outdoor use. The enclosure can be mounted to a structure using the through-box holes that are located outside of the gasket protection. The enclosure itself is designed to meet the IP65 waterproof standard. However, the enclosure should not be submerged in water.

### 2.2 Connectors and Cables

There are two connectors on the enclosure.

1. A BNC connector (Figure 2-1) is used to attach the wave probe head coax cable to the AWP-24-3 electronics.
2. A 6-pin circular male bayonet connector (Figure 2-2) is used to attach the instrumentation cable to the AWP-24-3. The instrumentation cable carries power to the electronics and carries the high-level output signal from the electronics to a remote data acquisition system or data recording device. The pin-out information for the connector and the instrumentation cable is shown in Table 2-1 below.

The instrumentation cable is not included with the AWP-24-3. We recommend using a high quality instrumentation cable with two shielded twisted pairs and a separate inner shield drain. One example of a suitable cable is Belden Cable part number 8723.

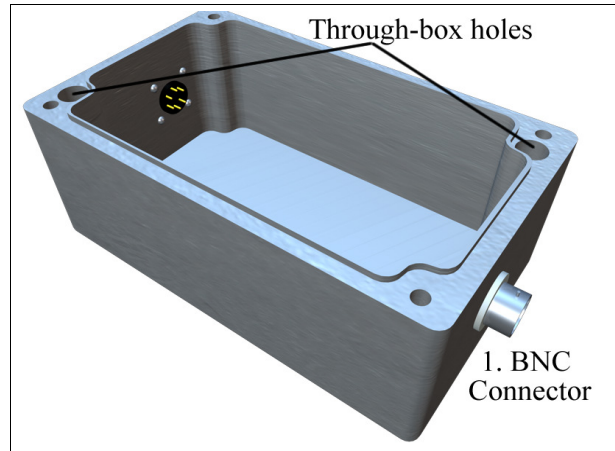

Figure 2-1: Enclosure & BNC Connector

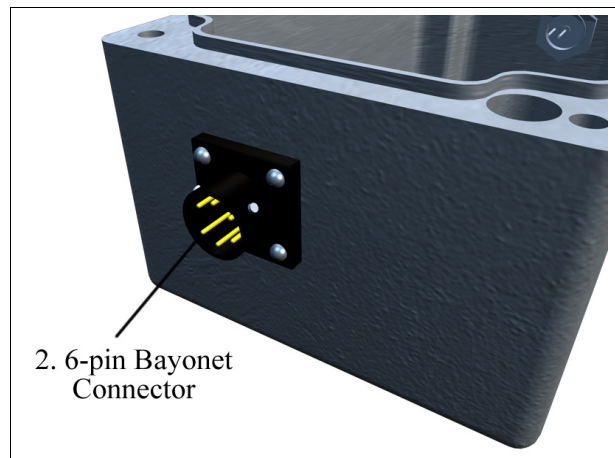

Figure 2-2: 6-pin Connector

	<ul style="list-style-type: none"> <li>● Pin A – N/C</li> <li>● Pin B – Output Signal High</li> <li>● Pin C – Output Signal Low</li> <li>● Pin D – Shield</li> <li>● Pin E – Power Low</li> <li>● Pin F – Power High</li> </ul>
---	---

Table 2-1: 6-pin Instrumentation Cable Connector

## 2.3 AWP-24-3 Electronics

The AWP-24-3 electronics measures capacitance and presents this as an analogue signal at the output. This signal is offset adjusted, amplified and filtered before being presented at the output connector. The output signal range is -4.5 volts to +4.5 volts.

The modest input power requirements must be provided by an external power supply. The power supply voltage should be between 8 VDC and 24 VDC maximum. The current draw of the board is approximately 16 mA. The circuit board is shown in Figure 2-3 below.

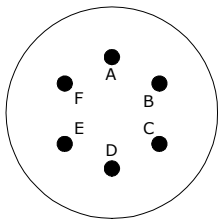
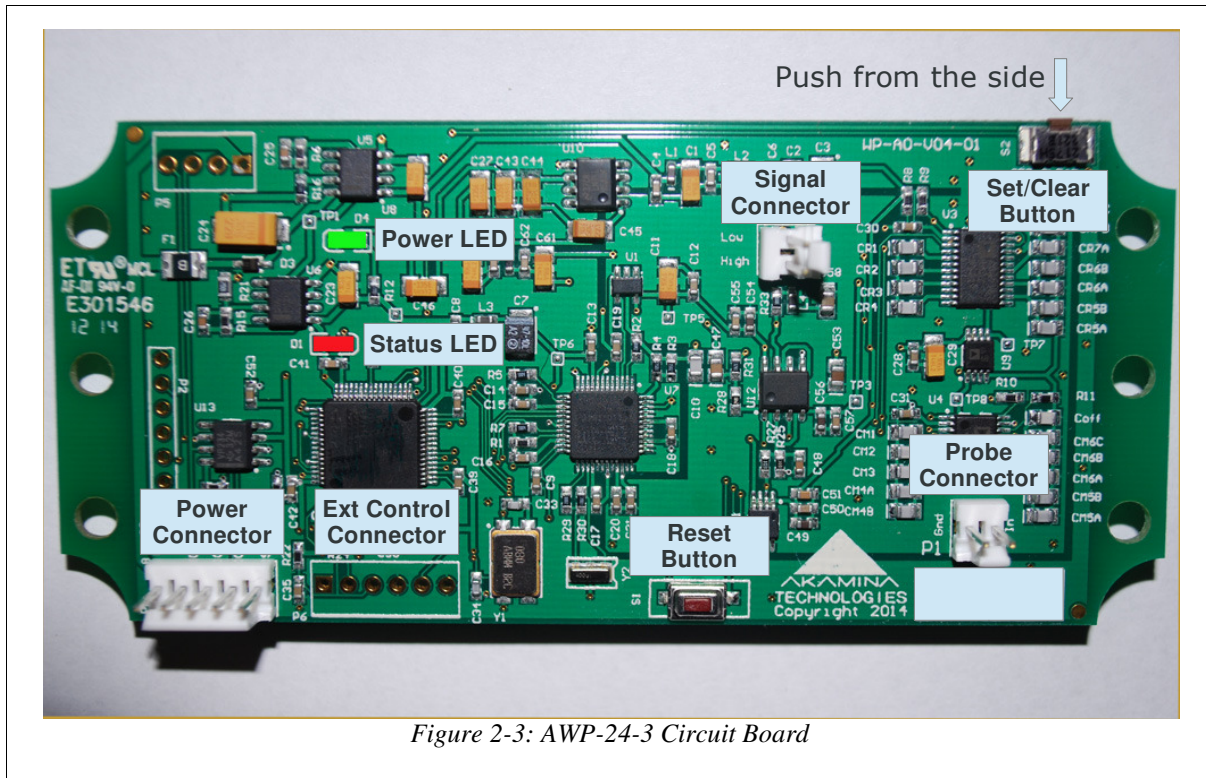

Figure 2-3: AWP-24-3 Circuit Board

The key components involved in the configuration of the circuit board are:

- Green Power LED – is illuminated green when the board is powered
- Red Status LED – shows the status of the board during configuration and normal operation
- Set/Clear – push button used to configure the electronics for different probe lengths and water depths. Please note that this button is pushed from the side
- Reset – push button used to reset the electronics
- External Control Connector – connector that provides access to the Power LED signal, Status LED signal and Set/Clear push button signal. This connector allows additional LEDs and Set/Clear push button to be mounted on the enclosure for easy access.

The remaining components and connectors on the circuit board are not user configurable and should not be touched.

## 2.4 External Control Connector

The Status LED, Power LED and the Set/Clear push button are only accessible by removing the top of the AWP-24 enclosure. In order to make it possible to monitor and to configure the wave height gauge without opening the enclosure, the necessary signals have been brought to a connector (P6) on the board. This allows a Status LED, a Power LED and / or a Set/Clear switch to be mounted on the enclosure and easily connected to the board.

The signals available on the external control connector are shown below in Figure 2-4. The Status LED+ is internally connected to 3.3V and Status LED- is switched between ground or +3.3V to turn the LED off or on. A 300  $\Omega$  resistor (R24) is used to limit the current flowing through the external Status LED. The Set/Clear connections allow an external normally-open push button to be mounted in parallel with the internal Set/Clear push button. The Power LED+ is internally connected to 3.3V and Power LED- is internally connected to ground. A 2k  $\Omega$  resistor (R23) is used to limit the current flowing through the external Power LED.

The MTA-100 header to be used on the board is part number: 640456-6 and the mating connector is part number 3-640440-6.

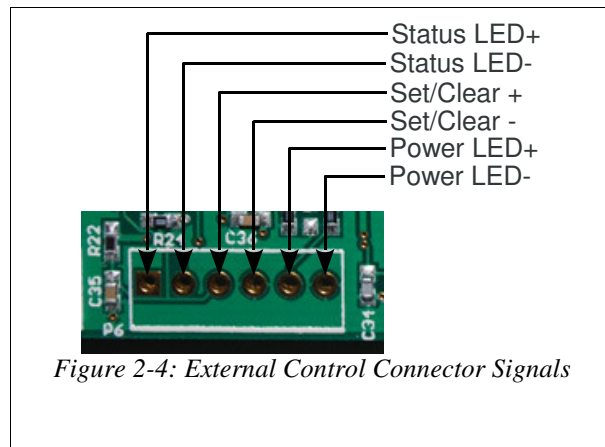

Figure 2-4: External Control Connector Signals

---

**CAUTION !** AWP-24-3 is a high precision instrument. When the enclosure lid is open, please follow safe ESD (Electrostatic Discharge) procedures in order to ensure problem free operation and to avoid damaging your instrument.

---

## 2.5 Wave Probe Head

The wave probe head provided with the AWP-24-3 is a high precision sensor and must be handled with care.

---

**CAUTION !** Please ensure that the sensing wire, shown in Figure 2-5, does not come into contact with sharp objects. When not in use, please do not put any weight on the sensing wire or let the wave probe head rest on the sensing wire. Avoid exposing the probe to extreme heat and cold.

---

For maximum measurement accuracy please do not exceed the maximum and minimum immersion limit recommendations shown in Figure 2-5. These limits should not be exceeded during configuration, calibration, and during normal operation. However, if you wish to use a smaller measurement range than the full range of the probe, you can use maximum and minimum levels that fall within the immersion limits shown in Figure 2-5 while performing the steps in sections 3. Configuration and 4. Output Range Adjustment.

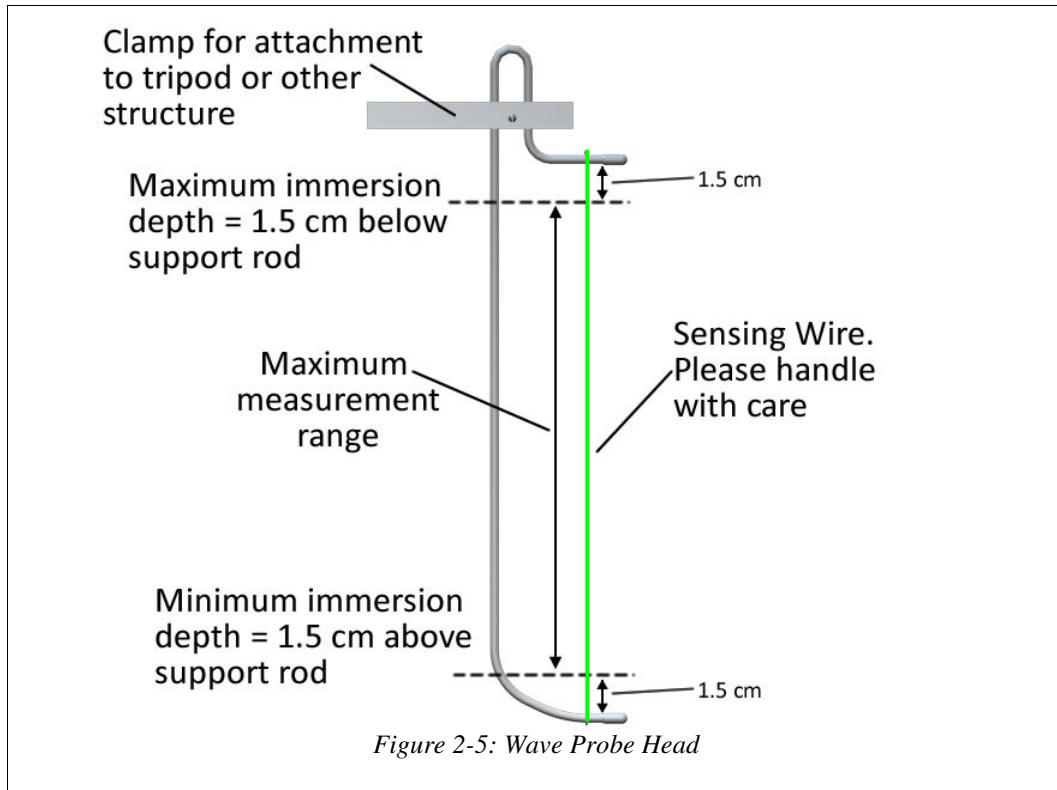

The AWP-24-3 does not include a stand or tripod. You will require a stand or tripod in order to place the wave probe head in water. The Akamina wave probe head comes with a clamp, shown in Figure 2-5. The clamp can be attached to a tripod or your specific support structure.



### 3. CONFIGURATION

---

The AWP-24-3 wave height gauge must be configured before it can be used. The configuration steps set the minimum automatically and set the maximum by immersing the probe to the maximum depth of the probe that you wish to use or to the maximum depth of the probe as shown in Figure 2-5.

#### **NOTE**

In the configuration steps described below you are asked to immerse the wave probe head in water. For accurate results please keep the water level constant and ensure that the water surface is steady, without any waves or ripples.

#### 3.1 Configuration Procedure

To configure the AWP-24-3 please follow these steps:

1. Open the enclosure top cover by unscrewing the 4 screws.
2. Connect the power wires of the instrumentation cable to a suitable power supply (8VDC – 24VDC maximum).
3. Connect the bayonet connector of the instrumentation cable to the 6-pin circular connector on AWP-24-3. The green PWR LED should be illuminated when the board is powered.
4. The red LED should be ON solid. If the red LED is not ON solid or if it is flashing, press and hold SET/CLEAR for 3 seconds. This will return the device to factory default settings.
5. Connect the wave probe head to the BNC connector on the AWP-24-3.
6. Immerse the probe to the maximum depth of water that you wish to measure or to the maximum depth of the probe as shown in Figure 2-5.
7. While the red LED is ON, press the SET/CLEAR push button once. The red LED will start flashing at 0.5 Hz; one second ON, one second OFF. Please do not move the wave probe head or disturb the water until the flashing has stopped.
8. When the 0.5 Hz flashing stops, the device is configured and ready to use. When the device is configured and operating properly the red LED flashes at the rate of 1 second ON, 9 seconds OFF.
9. If during configuration the LED starts flashing at 5 Hz the device was not able to configure properly. Please press the RESET button, then go back to step 4 and repeat the steps.

If you wish to clear all settings press and hold SET/CLEAR button for 3 seconds. This will return the device to factory default settings. The red LED should be ON solid after clearing the configuration.

The AWP-24-3 retains all settings when powered OFF. You do not need to repeat the above steps if the device has been powered OFF.

#### **NOTE**

The above steps configures the device to work with the minimum and maximum capacitance ranges of the the wave probe head. After the above steps the device is ready for use but the minimum voltage level associated with the minimum immersion level of the probe may be above -4.5V. To achieve the full range of the output voltage, -4.5V to + 4.5V, please go to the next section, 4. Output Range Adjustment.



## 4. OUTPUT RANGE ADJUSTMENT

---

After completing the configuration procedures in section 3. Configuration, the output range can be adjusted to maximize the output voltage range to approximately +/- 4.5 volts.

To adjust the output range please follow these steps:

1. Immerse the probe to the minimum depth of water that you wish to measure or to the minimum depth of the probe as shown in Figure 2-5.
2. While the red LED flashes at the rate of 1 second ON, 9 seconds OFF, press the SET/CLEAR push button once.
3. The red LED flashes quickly at 10Hz for 1 second after adjustment is completed. If you measure the output voltage now, it should be -4.5 volts. When the device is configured and operating properly the red LED flashes at the rate of 1 second ON, 9 seconds OFF.
4. Please note that step 2 can only be performed once. If you need to adjust the output range again you must repeat the steps in section 3. Configuration.

If you wish to clear all settings press and hold SET/CLEAR button for 3 seconds. This will return the device to factory default settings. The red LED should be ON solid after clearing the configuration.

The AWP-24-3 retains all settings when powered OFF. You do not need to repeat the above steps if the device has been powered OFF.

### 4.1 Calibration

The first step before proceeding with actual measurements is to perform a calibration. This is necessary in order to determine the relationship between water depth and the output voltage from AWP-24-3. We recommend the following guidelines for calibration.

1. The calibration points should span the range of water depths that are to be measured.
2. Use a minimum of 3 points in the calibration. The additional points allow errors to be computed that should be used to verify the calibration procedure and the wave height gauge.
3. The depth of water at each calibration point must be more accurate than the desired accuracy of wave height measurements.
4. The AWP-24-3 is a highly linear device; always compute the best-fit-straight line through the calibration points.
5. Perform the calibration in steady water with no waves or ripples.

## 5. MINOR ADJUSTMENTS TO SENSING WIRE TENSION

---

The sensing wire on the wave probe head must have enough tension to ensure accuracy and linearity of measurements. If the sensing wire has become loose over time please follow these instructions in order to correct the tension of the wire.

Please note that this procedure is only used for small adjustments. If the wire has been damaged or is very loose please refer to the document, “[Short Probe Wire Replacement Procedure.pdf](#)”, for instructions on how to replace the wire or make larger tension adjustments.

### 5.1 Instructions

1. Bend the two ends of the wave probe head supporting rod together in order to remove any tension on the sensing wire.
2. Carefully remove the wire from the top and bottom grommets but do not untie the knot on the top.
3. Once the wire is off, bend the supporting rod outward slightly as shown in figure 5-1 below. The red arrows show the placement and direction of force to be applied. This increases the distance between the two ends of the rod. The rod should not be bent too much.
4. Put the wire back on and the rod and the increased distance should make the wire tighter.

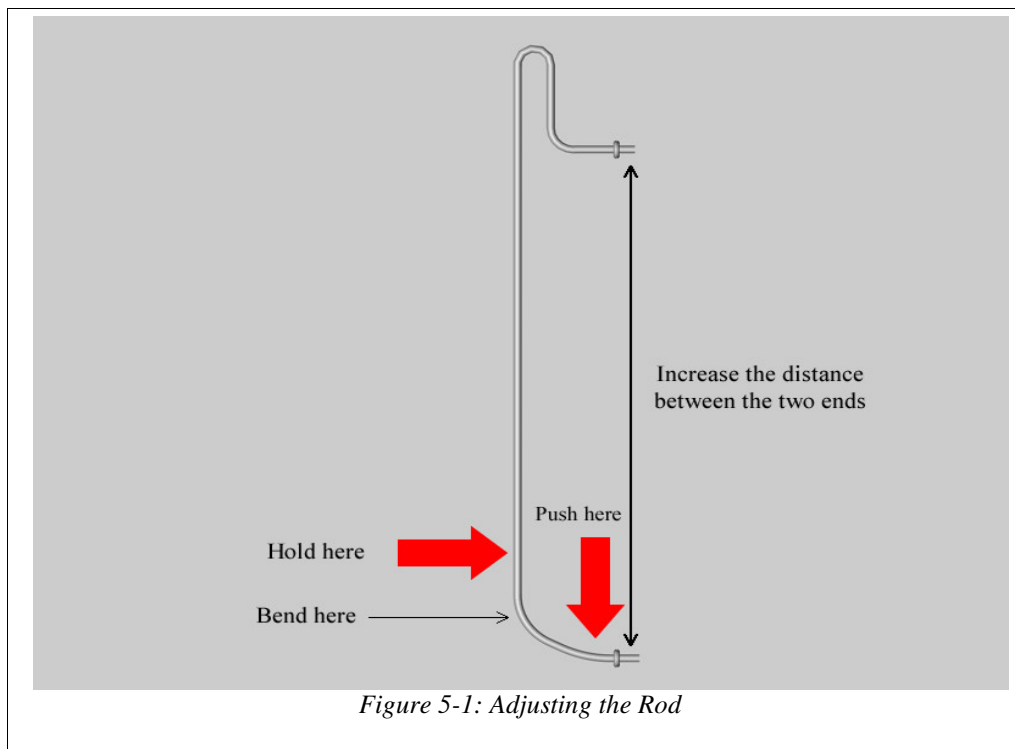



## **6. AKAMINA PRODUCT WARRANTY**

---

### **6.1 Limited Warranty**

Akamina Technologies Inc. (“Akamina”) manufactures (or has manufactured by a third party) its hardware products from parts and components that are new or equivalent to new in accordance with industry-standard practices. Akamina warrants that hardware products supplied by Akamina will be free from defects in materials and workmanship under normal use for a period of one (1) year from the date of shipment to the original purchaser.

This warranty does not cover consumables, such as sensing wire on the wave probe heads, normal wear and tear, damage due to external events, including accident, acts of God, abuse, misuse, problems with electrical power source, attempted modifications or servicing not authorized by Akamina, negligent use or mishandling, and problems caused by use with non-Akamina products, external devices, accessories or parts added to the system.

### **6.2 Remedies**

During the limited warranty period Akamina will, at its option, repair, replace or refund the purchase price of products that are determined to be defective. Replacement may constitute, at Akamina’s option, a new, refurbished or functionally equivalent item. A replacement product or part assumes the remaining warranty of the original product or ninety (90) days from the date of replacement or repair, whichever provides longest coverage.

To request limited warranty service, the purchaser must contact Akamina within the limited warranty period. If warranty service is required pursuant to the limited warranty the purchaser will pay for and ship the defective product(s) item to Akamina. Akamina will ship the repaired or replacement product(s) to the purchaser or refund the purchase price of the defective product(s).